

Maxonic

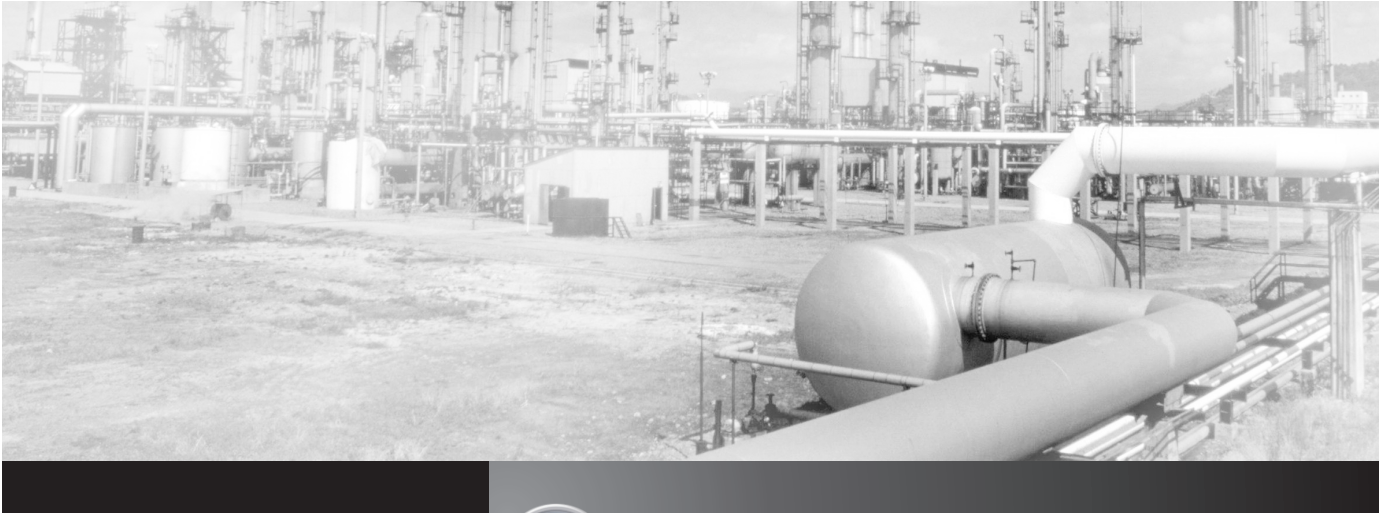

MVP SMART VALVE POSITIONER
⇒ MVP3800 Quick Start Guide

THESE INSTRUCTIONS PROVIDE THE CUSTOMER/OPERATOR WITH IMPORTANT PROJECT-SPECIFIC REFERENCE INFORMATION IN ADDITION TO THE CUSTOMER/OPERATOR'S NORMAL OPERATION AND MAINTENANCE PROCEDURES.

THESE INSTRUCTIONS ASSUME THAT OPERATORS ALREADY HAVE A GENERAL UNDERSTANDING OF THE REQUIREMENTS FOR SAFE OPERATION OF MECHANICAL AND ELECTRICAL EQUIPMENT IN POTENTIALLY HAZARDOUS ENVIRONMENTS. THEREFORE, THESE INSTRUCTIONS SHOULD BE INTERPRETED AND APPLIED IN CONJUNCTION WITH THE SAFETY RULES AND REGULATIONS APPLICABLE AT THE SITE AND THE PARTICULAR REQUIREMENTS FOR OPERATION OF OTHER EQUIPMENT AT THE SITE.

THESE INSTRUCTIONS DO NOT PURPORT TO COVER ALL DETAILS OR VARIATIONS IN EQUIPMENT NOR TO PROVIDE FOR EVERY POSSIBLE CONTINGENCY TO BE MET IN CONNECTION WITH INSTALLATION, OPERATION OR MAINTENANCE. SHOULD FURTHER INFORMATION BE DESIRED OR SHOULD PARTICULAR PROBLEMS ARISE WHICH ARE NOT COVERED SUFFICIENTLY FOR THE CUSTOMER/OPERATOR'S PURPOSES THE MATTER SHOULD BE REFERRED TO MAXONIC.

THESE INSTRUCTIONS ARE FURNISHED TO THE CUSTOMER/OPERATOR SOLELY TO ASSIST IN THE INSTALLATION, TESTING, OPERATION, AND/OR MAINTENANCE OF THE EQUIPMENT DESCRIBED. THIS DOCUMENT SHALL NOT BE REPRODUCED IN WHOLE OR IN PART WITHOUT THE WRITTEN APPROVAL OF MAXONIC.

Introduction

MVP smart valve positioner is a user friendly digital valve positioner for pneumatic control valves. Utilizing advanced control and diagnostical gorithms, along with field-proven non contact position sensing technology, the MVP delivers accurate, responsive and reliable posioning performance.



Electrical connection

Terminal name	Signal name	Function
1+	Current input signal(+)	Connect the 4–20 mA control signal to this terminal to supply power and signal to the positioner.
2-	Current input signal(-)	
11+	Current output signal(+)	4–20 mA analog feedback signal indicating the current valve position.
12-	Current output signal(-)	
21+	Switch output signal1(+)	Alarm output 1: When the valve operates to the set alarm position, Output switch signals that comply with the NUMAR standard.
22-	Switch output signal1(-)	
31+	Switch output signal2(+)	Alarm output 2: When the valve operates to the set alarm position, Output switch signals that comply with the NUMAR standard.
32-	Switch output signal2(-)	

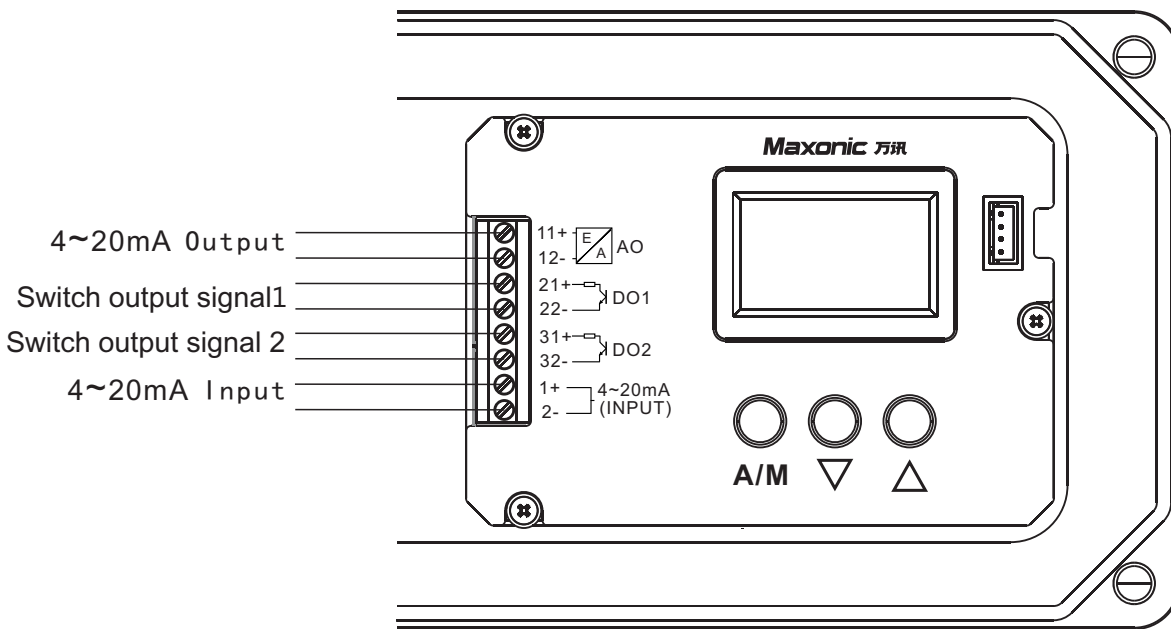

Mounting

Determine the location for installing the locator based on the process system design specifications and the performance characteristics of the specific model released by MAXONIC.

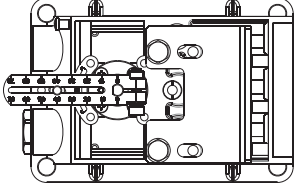
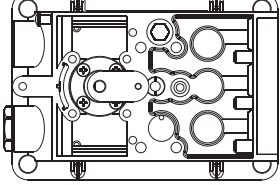
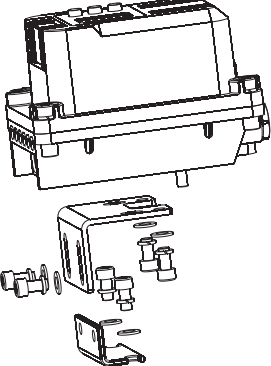
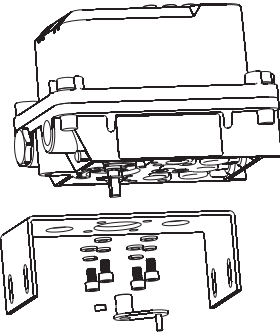
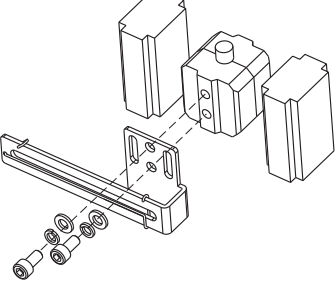
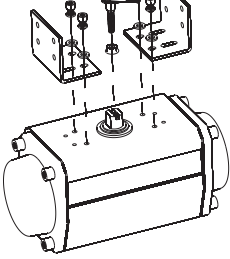
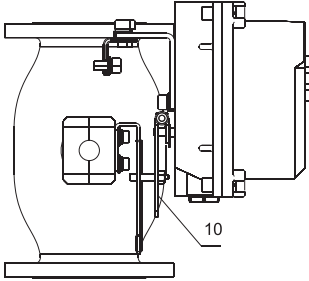
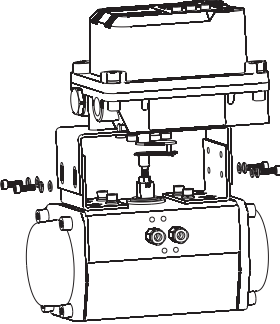
<p>Mounting Procedure of MVP on Reciprocating Control Valves</p>	<p>Mounting Procedure of MVP on Rotary Control Valves</p>
<p>1. MVP positioner is mounted on a linear actuator with standard feedback lever. The recommended feedback angle is from 40° to 60° on a linear actuator.</p>	<p>1. MVP positioner is mounted on a rotary actuator with standard feedback lever.</p>
	
<p>2. Fix the positioner bracket to the positioner.</p>	<p>2. Fix the positioner bracket to the positioner.</p>
	
<p>3. Fix the feedback bracket to the actuator.</p>	<p>3. Fix the feedback bracket to the actuator.</p>
	
<p>4. Fix the positioner to the actuator.</p>	<p>4. Fix the positioner to the actuator.</p>
	

Operation interface

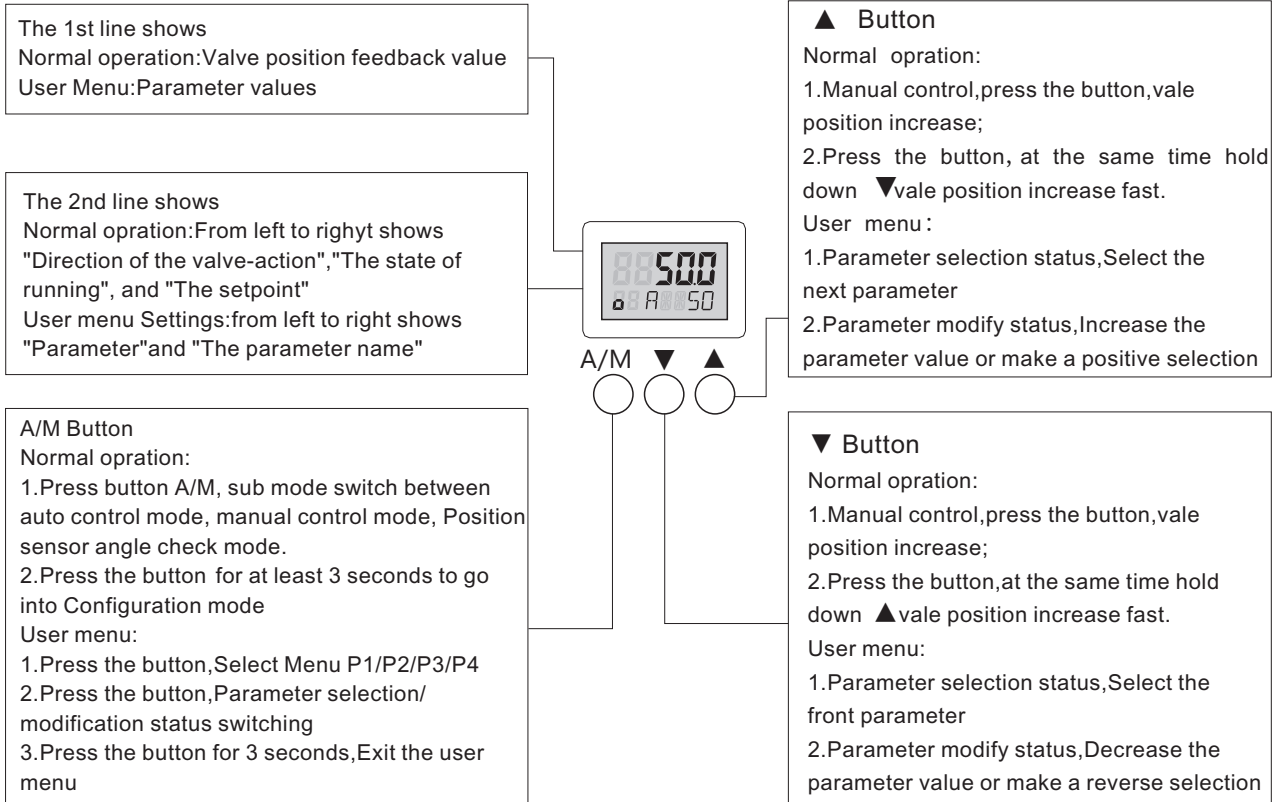

User menu

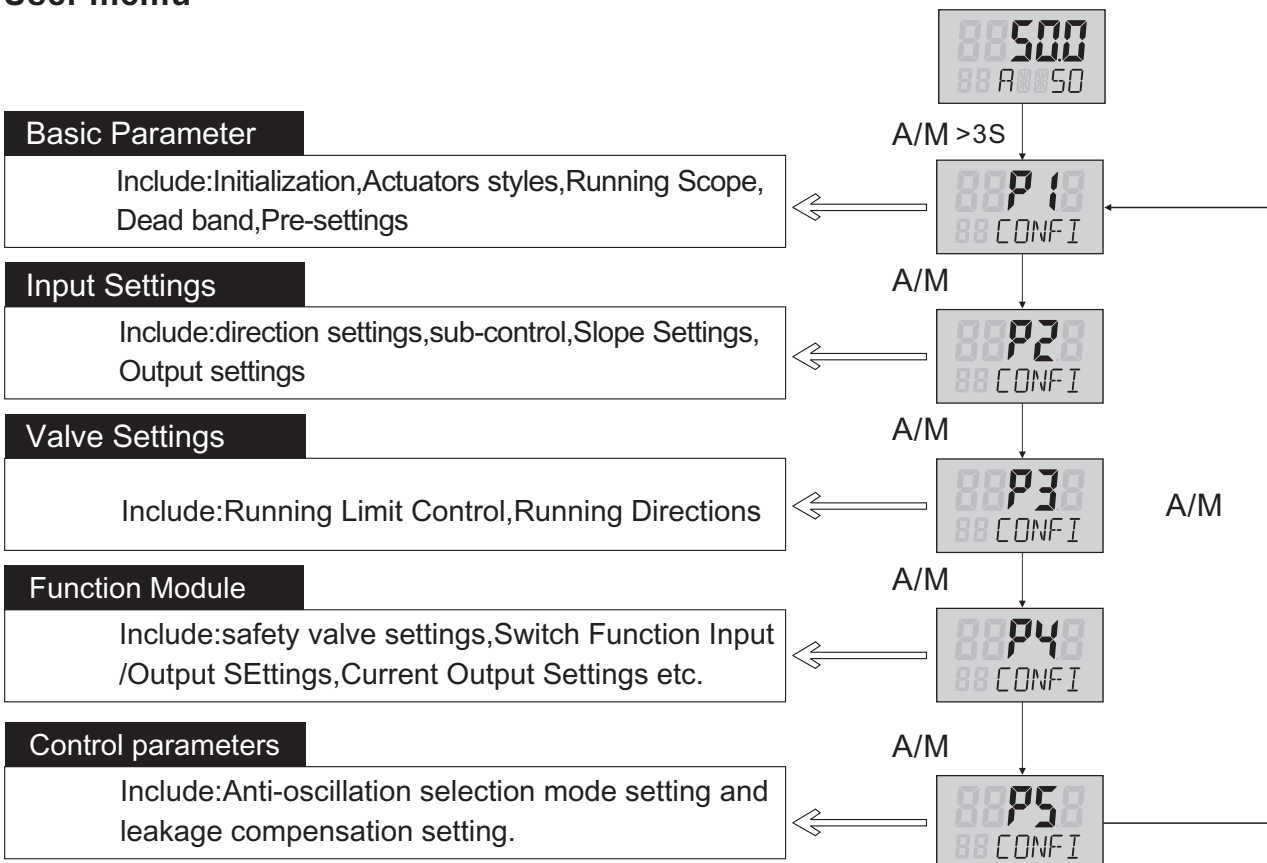

Commissioning

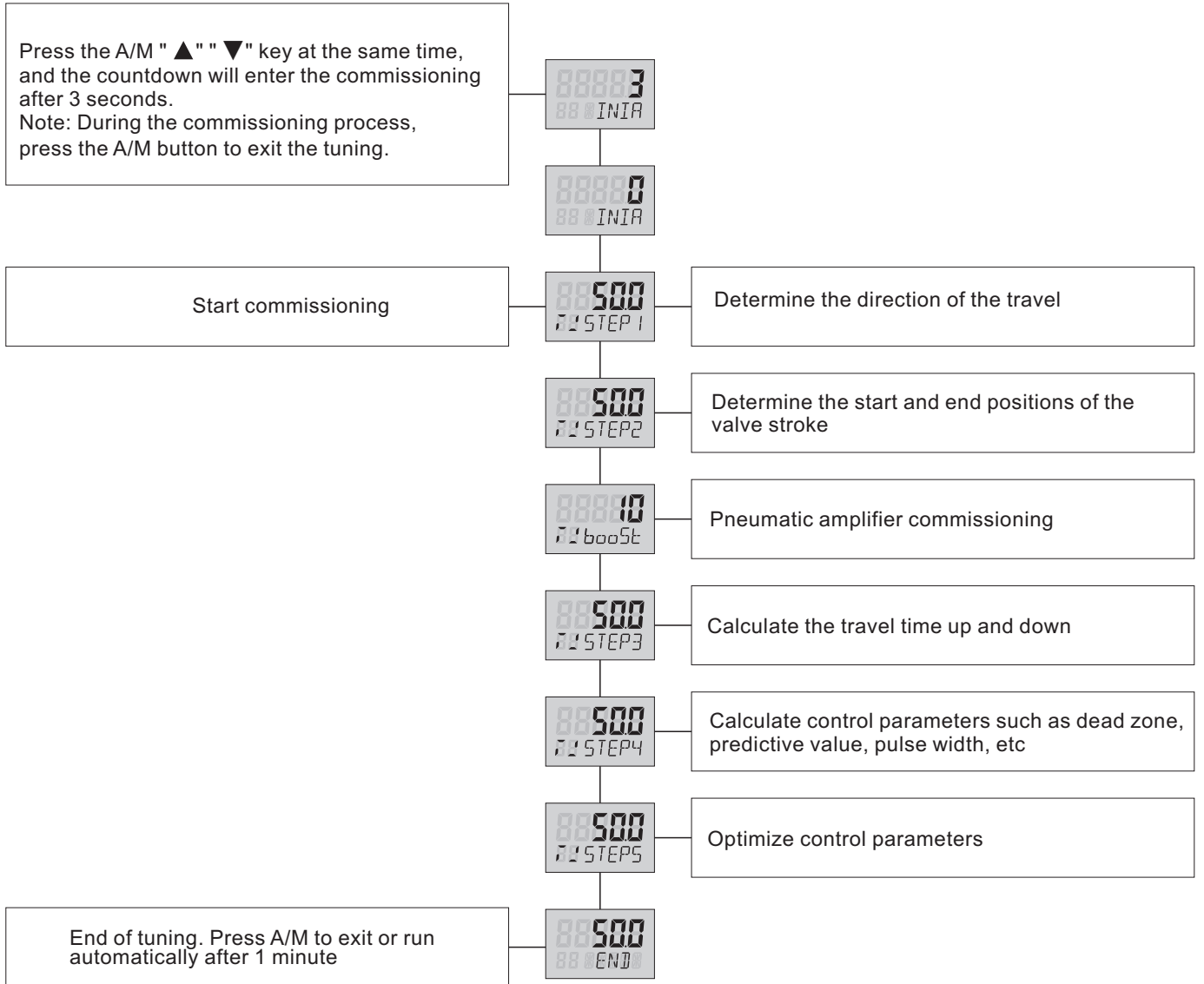

Troubleshooting

The MVP3800 performs internal self-diagnostics and hardware checks. When the local display indicates that there are error messages, then use the following sections to support troubleshooting.

Control Status Diagnostics

Display code	Cause	Recommended Actions
8862ER	> 30 seconds valve still not actuated properly	Cleaning valve; Check the valve institutions.

Measure Status Diagnostics

Display code	Cause	Recommended Actions	
SVL	Set current < 3.6mA	Increase input current $\geq 3.8\text{mA}$	
SVH	Set current > 21mA	Reduce input current $\leq 20.5\text{mA}$	
FbL	Feedback < -10%	Adjust the feedback connection	Feedback $\geq -1\%$
FbH	Feedback > 110%		Feedback $\leq 103\%$
FbADN	Feedback angle < -85°		Feedback angle $\geq -82.5^\circ$
FbAUP	Feedback angle > 85°		Feedback angle $\leq 82.5^\circ$
TEL	Working environment temperature < 45°C	Check and adjust the ambient temperature	
TEH	Working environment temperature > 85°C		

System Status Diagnostics

Display code	Cause	Recommended Actions
EPER	Control timeout (Valve jam)	Reset parameters or factory reset
ADJER	ADC sampling overflow	Check and debug the motherboard

Commissioning Status Diagnostics

Display code	Cause	Recommended Actions
RERR	Commissioning timeout	<ol style="list-style-type: none"> 1. Check the air supply pressure; 2. In manual control mode, check whether the valve can be moved up and down; 3. Check if the pneumatic output have gas.
DOWN	Zero point of position sensor too low , < -85°	Adjust the feedback connection
UP	Span point of position sensor too low , > 85°	
UPDW	The feedback range < 10%	
SET	$0^\circ < \text{Feedback angle} < 85^\circ$ or $-85^\circ < \text{Feedback angle} < 0^\circ$	

Maxonic

SHENZHEN MAXONIC AUTOMATION CONTROL CO.,LTD.

Address: 1-6F Maxonic Building, No.3 Road, North Area of High-Tech Industrial Park, Nanshan District,
Shenzhen City, Guangdong Province, China

Tel: 0755-86250388 Fax: 0755-86250389

Manufacturer : ShenZhen MAXONIC Automation Control co.,Ltd.

Production address : JiangYin China

<http://www.maxonic.com.cn>

E-mail:info@maxonic.com.cn

4000 300 112